

GUIDANCE NOTE

Irish Sea Cod Conservation Measures 2018

APPROVED TR2 HIGHLY SELECTIVE GEAR 2018



Introduction

- DAERA administered vessels using TR2 fishing gear within the Cod Recovery Zone are required to have a Fishing Authorisation under Article 10(1) of Council Regulation 1342/2008.
- DAERA is retaining cod conservation measures for vessels targeting Nephrops in order to maintain progress towards cod recovery and to ensure that the UK stays within its by-catch only quota for Irish Sea cod. For 2018 this is 200 tonnes.
- 1st January 2018 to 31st December 2018 vessels targeting Nephrops in the Irish Sea with TR2 gear must use one of the following approved Highly Selective fishing gears within the Irish Sea.
 1. Seltra “300” Trawl (4m box section with 300 mm square mesh)
 2. Seltra “270” Trawl (3m box section with 270 mm diamond mesh)
 3. Faithlie Panel
 4. Flip – Flap trawl
 5. CEFAS Net Grid
 6. Inclined separator panel (specification as per the Annex to EC 254/2002)
 7. Swedish Grid (specification as per the Appendix 2 to Annex III of EC 43/2009)
 8. 200 square mesh panel (only available for vessels 12 metres and under)
 9. 300 square mesh panel (available for all vessels)
- When fishing within the CRZ outside the Irish Sea vessels may use any of the above gears or an alternative TR2 gear acceptable to the relevant Fisheries Administration for that area. Vessels should contact the relevant Fisheries Administration for advice.
- Trials of highly selective gears will continue throughout 2018 and any new gears that prove to be highly selective will be added to this list.
- Existing gears that are significantly outperformed by new gears may be removed from the list.
- This Guidance Note provides specifications for each of the highly selective gears listed.

1. Seltra “300” Trawl (4m box section with 300 mm square mesh)

The Seltra “300” trawl comprises a 4 metre box section located in straight section of the cod end. The top panel is made of large square mesh that is intended to encourage whitefish, especially cod, to escape whilst Nephrops travel along the bottom of the section to the rear of the cod end.

This device is considered by the STECF to be highly selective and reduces cod catch to below 1.5%.

Specifications to be read along with the illustration below:

Box Section Extension

The trawl must include a box section (4 panel) extension to the cod end with the top panel of the box section made up of “300mm” square mesh of no less than 4 metres in length.

Nets 70mm or 80mm with up to 120 open meshes

Top panel

Minimum of 4 metres long of square mesh of at least “300 mm” mesh size.

For knotted netting, the “300” is measured as the distance between the centre of the two opposite knots in the same mesh when fully extended. As this measurement cannot be made with an Omega Gauge manual measurement is required. A maximum tolerance of 10mm is allowed. Any mesh that is less than 290 mm knot centre to knot centre measured diagonally across the extended square may not be used. The bar length shall be at least 150mm between the centre of sequential knots. The panel shall be 4 bars wide.

Bottom and Side panels

Each panel is to be made up of 70 or 80mm diamond mesh, up to 30 open meshes wide plus selvedge meshes at each side. The bottom panel should be the same as the top square mesh panel (maximum length to be no shorter than 3% shorter than the equivalent square mesh panel). Side panels must be at least the same length but can be extended and tapered to provide a better “fit”.

Location

The box section is to be fitted between the end of the tapered section of the trawl and the cod end. The forward edge of the square mesh panel is to be within 1.5m of the end of the taper of the trawl.

Nets 70mm or 80mm with up to 100 open meshes

Top panel

Minimum of 4 metres long of square mesh of at least 300mm mesh size. For knotted netting, this is measured as the distance between the centre of the two opposite knots in the same mesh when fully extended. As this measurement cannot be made with an Omega Gauge manual measurement is required. A maximum tolerance of 10mm is allowed. Any mesh that

is less than 290 mm knot centre to knot centre measured diagonally across the extended square may not be used. The bar length shall be at least 150mm between the centre of sequential knots. The panel shall be 4 bars wide.

Bottom and Side panels

Each panel is to be made up of 70 or 80mm diamond mesh, up to 25 open meshes wide plus selvedge meshes at each side. The bottom panel should be the same as the top square mesh panel (maximum length to be no shorter than 3% shorter than the equivalent square mesh panel). Side panels must be at least the same length but can be extended and tapered to provide a better “fit”.

Location

The box section is to be fitted between the end of the tapered section of the trawl and the cod end. The forward edge of the square mesh panel is to be within 1.5m of the end of the taper of the trawl.

Improving performance of the Seltra Trawl

The following points may help to improve the performance of the Seltra Trawl

- The box section should be located as close to the tapered section as possible.
- As far as possible the overall length of the cod end should be similar to the existing cod end in use.
- The transition from two panel to four panel can be improved by adding a tapered section to the side panels at either end of the box section (see diagram). The tapered sections can be whatever length is required to achieve a satisfactory result.
- Stability of the cod end to the rear of the box section may be improved by making the entire cod end square ie 4 panel.
- Trial gear did not use strengthening ropes. If used they should be along length of sides of the box section top square mesh panel. These ropes to be no thicker than 18mm diameter.
- Trial gear did not use floats. If used, one small float of no more than 6 inches placed at each corner of the box section square mesh panel may help stability. Floats should not be placed along the middle of the top panel of the boxed section. Too much buoyancy may lift the box section too much and adversely affect performance.

Additional Square Mesh Panel

The trawl must also include a square mesh panel made of at least 90mm square mesh located in the top panel of the taper of the trawl.

- The window shall be a rectangular section of netting. The netting shall be single twine. The meshes shall be square meshes, i.e. all four sides of the window netting shall be cut all bars.

- The mesh size shall be equal or more than 90mm. The length of the window shall be at least 3m.
- There shall be no more than five open diamond meshes between the longitudinal side of the window and the adjacent selvedge. The strength length of the window shall be equal to the strength length of the diamond meshes attached to the longitudinal side of the window. The joining rate between the diamond meshes of the top panel of the cod end and the smallest side of the window shall be three diamond meshes to one square mesh for 80 mm cod end, or two diamond meshes to one square mesh for 120 mm cod end, except for edge bars of the window from both sides.

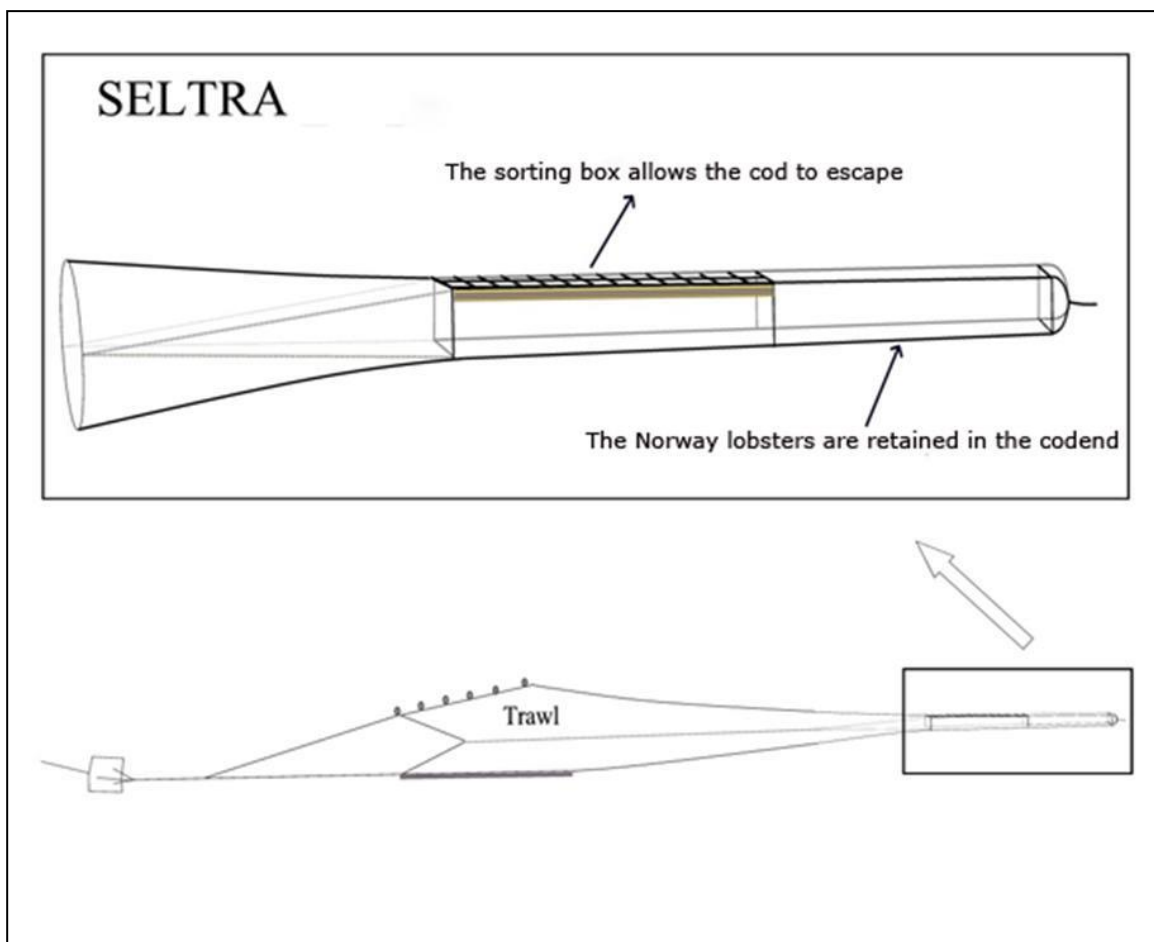

Box Section Dimensions for 70 or 80mm netting with 100 or 120 open meshes in the extension and cod end

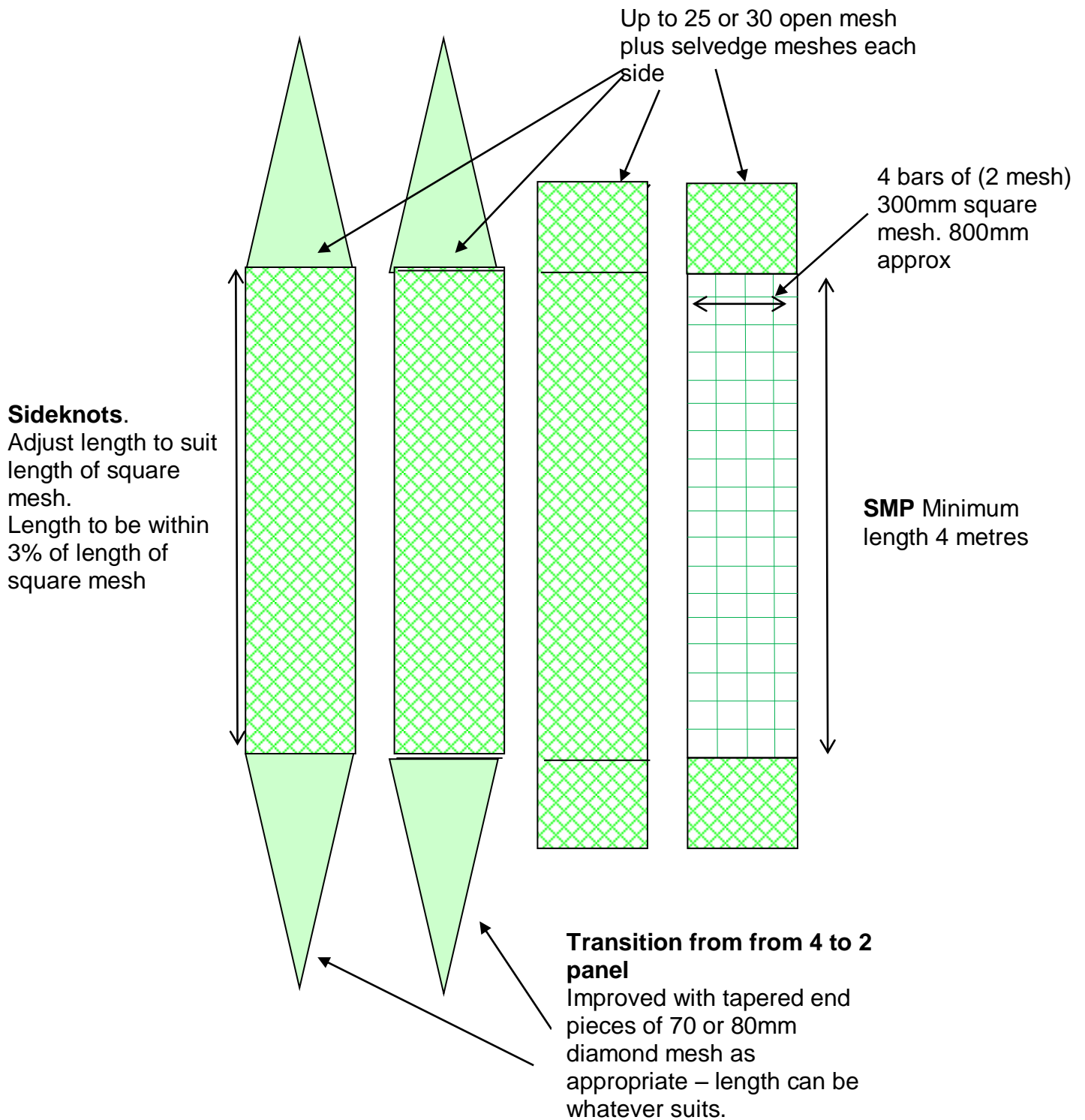

2. Seltra “270” Trawl (3m box section with 270 mm diamond mesh)

The Seltra “270” trawl comprises a 3 metre box section located in the straight section of the cod end. The top panel is made of large diamond mesh that is intended to encourage whitefish, especially cod, to escape whilst Nephrops travel along the bottom of the section to the rear of the cod end.

Specifications to be read along with the illustration below:

Box Section Extension

The trawl must include a box section (4 panel) extension to the cod end with the top panel of the box section made up of 270mm diamond mesh of no less than 3 metres in length.

Nets 70mm or 80mm with up to 120 open meshes

Top panel

Minimum of 3 metres long of diamond mesh of at least 270mm mesh size. The panel shall be at least 800mm wide when open.

Bottom and Side panels

Each panel is to be made up of 70 or 80mm diamond mesh, up to 30 open meshes wide plus selvedge meshes at each side. The bottom panel should be the same as the top square mesh panel (maximum length to be no shorter than 3% shorter than the equivalent square mesh panel). Side panels must be at least the same length but can be extended and tapered to provide a better “fit”.

Location

The box section is to be fitted between the end of the tapered section of the trawl and the cod end. The forward edge of the square mesh panel is to be within 1.5m of the end of the taper of the trawl.

Nets 70mm or 80mm with up to 100 open meshes

Top panel

Minimum of 3 metres long of diamond mesh of at least 270mm mesh size. The panel shall be at least 800mm wide when open.

Bottom and Side panels

Each panel is to be made up of 70 or 80mm diamond mesh, up to 25 open meshes wide plus selvedge meshes at each side. The bottom panel should be the same as the top square mesh panel (maximum length to be no shorter than 3% shorter than the equivalent square mesh panel). Side panels must be at least the same length but can be extended and tapered to provide a better “fit”.

Location

The box section is to be fitted between the end of the tapered section of the trawl and the cod end. The forward edge of the square mesh panel is to be within 1.5m of the end of the taper of the trawl.

Improving performance of the Seltra Trawl

The following points may help to improve the performance of the Seltra Trawl

- The box section should be located as close to the tapered section as possible.
- As far as possible the overall length of the cod end should be similar to the existing cod end in use.
- The transition from two panel to four panel can be improved adding a tapered section to the side panels at either end of the box section (see diagram).
- Stability of the cod end to the rear of the box section may be improved by making the entire cod end square ie 4 panel.
- Strengthening ropes if used should be along length of sides of the box section top square mesh panel. These ropes to be no thicker than 18mm diameter.
- Floats if used – only one small float of no more than 6 inches placed at each corner of the box section large diamond mesh panel may help stability. Floats should not be placed along the middle of the top panel of the boxed section. Too much buoyancy may lift the box section too much and adversely affect performance.

Additional Square Mesh Panel

The trawl must also include a square mesh panel made of at least 90mm square mesh located in the top panel of the taper of the trawl.

- The window shall be a rectangular section of netting. The netting shall be single twine. The meshes shall be square meshes, i.e. all four sides of the window netting shall be cut all bars.
- The mesh size shall be equal or more than 90mm. The length of the window shall be at least 3m.
- There shall be no more than five open diamond meshes between the longitudinal side of the window and the adjacent selvedge. The strength length of the window shall be equal to the strength length of the diamond meshes attached to the longitudinal side of the window. The joining rate between the diamond meshes of the top panel of the cod end and the smallest side of the window shall be three diamond meshes to one for a square mesh for 80 mm cod end, or two diamond meshes to one square mesh for 120 mm cod end, except for edge bars of the window from both sides.

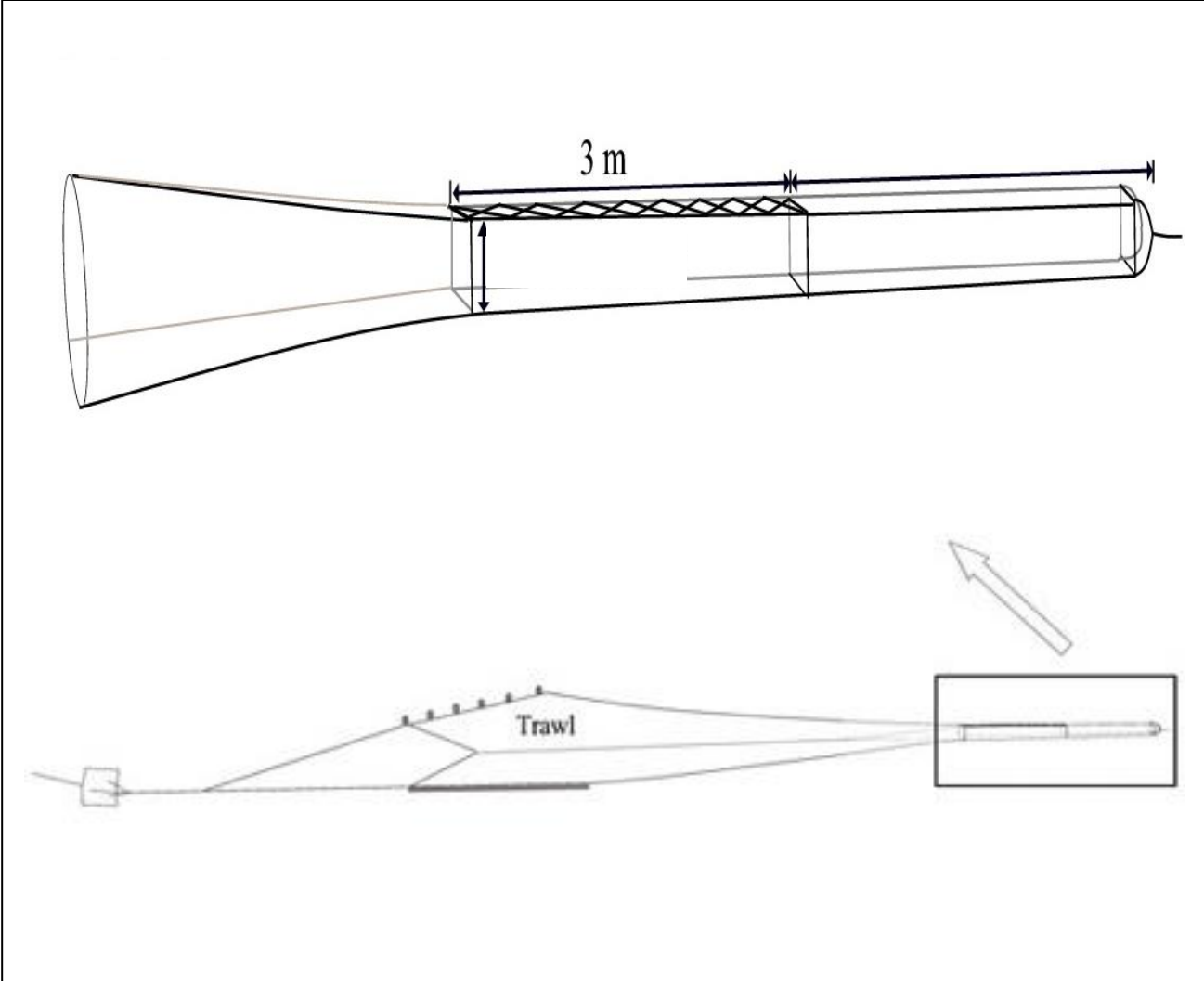

Box Section Dimensions for 70 or 80mm netting with 100 or 120 open meshes in the extension and cod end

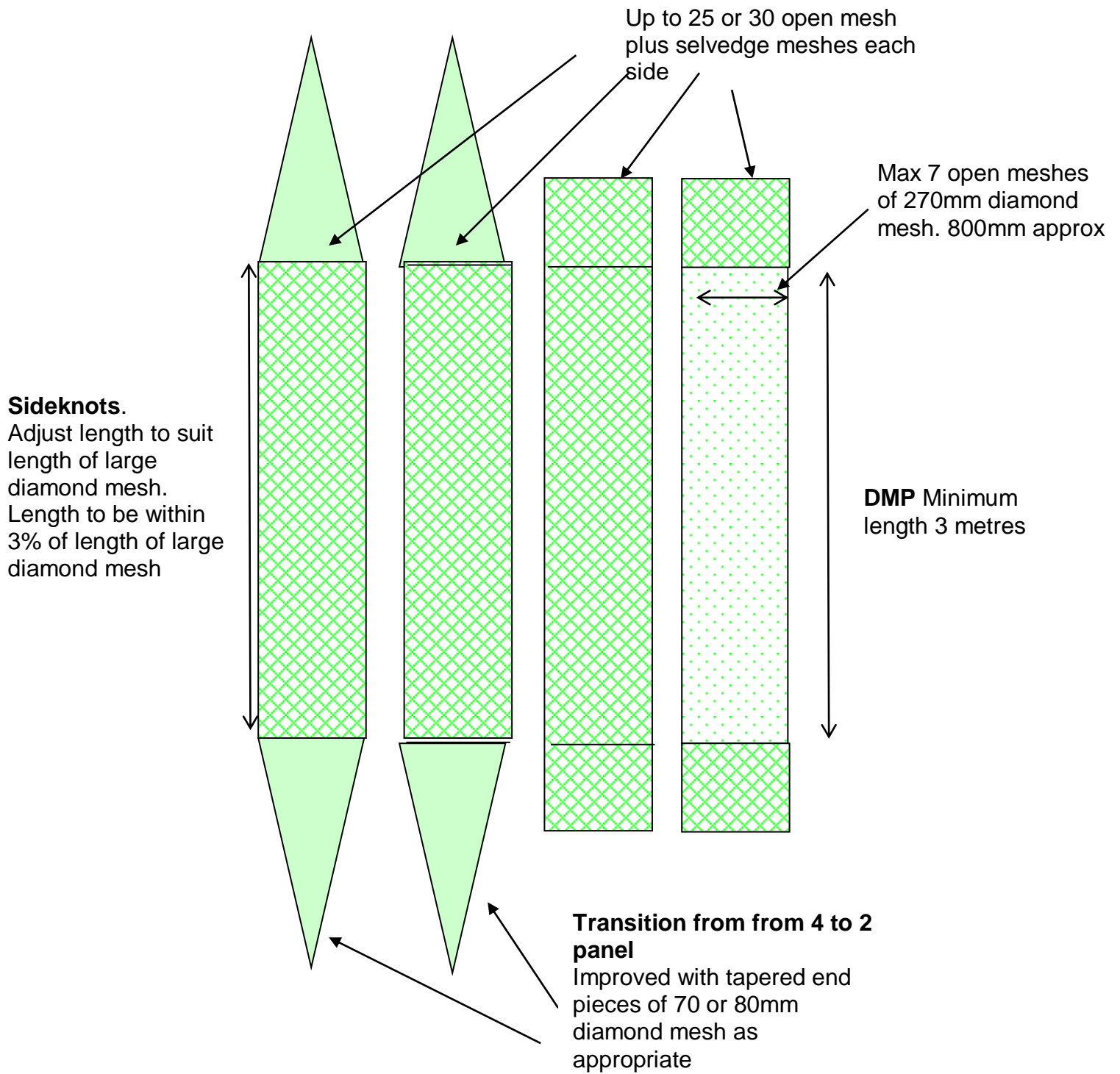

3. Faithlie Panel

The Faithlie Panel comprises a large square mesh netting separator panel that is intended to create a physical barrier to whitefish, especially cod, whilst allowing the passage of Nephrops through to the cod end.

Specifications to be read along with the illustration below:

Design of Inclined Panel

1. The Faithlie Cod Avoidance Panel is made from netting of mesh size of at most 300mm and of twine thickness (in the flip flap netting and in attachment to the main body of the net) of no less than 4mm single.
2. It is hung on the square and is 8 bars in height and 14 bars wide.
3. It is cut out as shown in figure 1.
4. It can be roped around the perimeter in such a way so as not to distort the panel when laid flat (figure 2).
5. To allow the passage of benthos and ground fish species, it is permitted to create a hole at the bottom of the panel, by cutting out the mesh bars shown in figure 1. For strength and integrity the perimeter of the hole must be roped with a rope whose length is no more than 2.1m and whose diameter is no more than 12mm (figure 2).

Positioning of Panel

6. Attachment points A are fitted to the selvages in the tapered section of the gear where there are 200 open 80mm meshes (or equivalent) in circumference.
7. Attachment point B is fitted to the centre of the top sheet 3½ meshes aft of the cross section that is described by attachment point A.
8. Attachment point C is fitted to the centre of the bottom sheet 3½ meshes forward of the cross section that is described by attachment point A (figure 3).
9. The perimeter of panel is fitted to the trawl netting, length for length, between the attachment points.

Fish Outlet Holes

10. Two unblocked fish outlet holes (with clean meshes all the way around) must be cut out of the trawls top sheet netting not more than two meshes ahead of the inclined panel at any point.
11. They must be positioned 2 x 80mm diamond meshes (or equivalent) meshes either side of the centre line.
12. The opening width of the posterior side of these fish outlets should be no less than 28 x 80mm diamond meshes (or equivalent) across and cut out in the forward direction along mesh bars until there are 9 open meshes across (figure 3).

Flotation

13. Flotation may be used with the above TR2 gears. It is only permitted, however, along the line where the internal netting panel is attached to the top sheet netting and/or along the sides of the fish outlet holes.

14. Along the line where the internal netting panel is attached to the top sheet netting, the maximum size of floats is 125mm in diameter by 155mm in length.
15. Along the sides of the fish outlet hole, the floats must be fitted at least 2 open meshes from the edge of the hole. The maximum size of these floats is 60mm in diameter by 120mm in length
16. All floatation must be fitted securely against the top netting sheet.

**Inclined Panel
Figure 1**

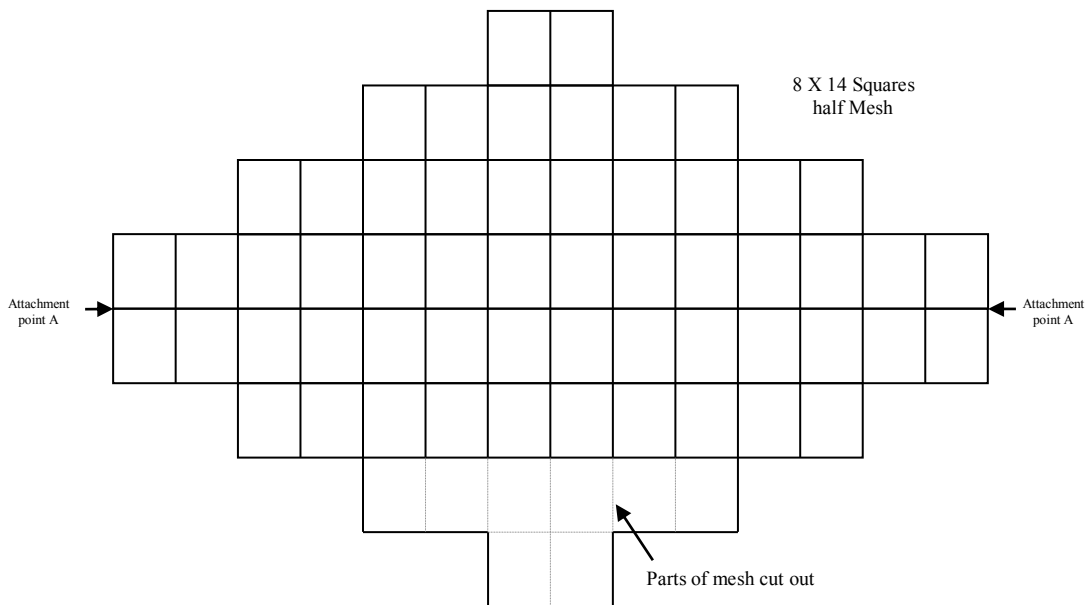

**Inclined Panel
Figure 2**

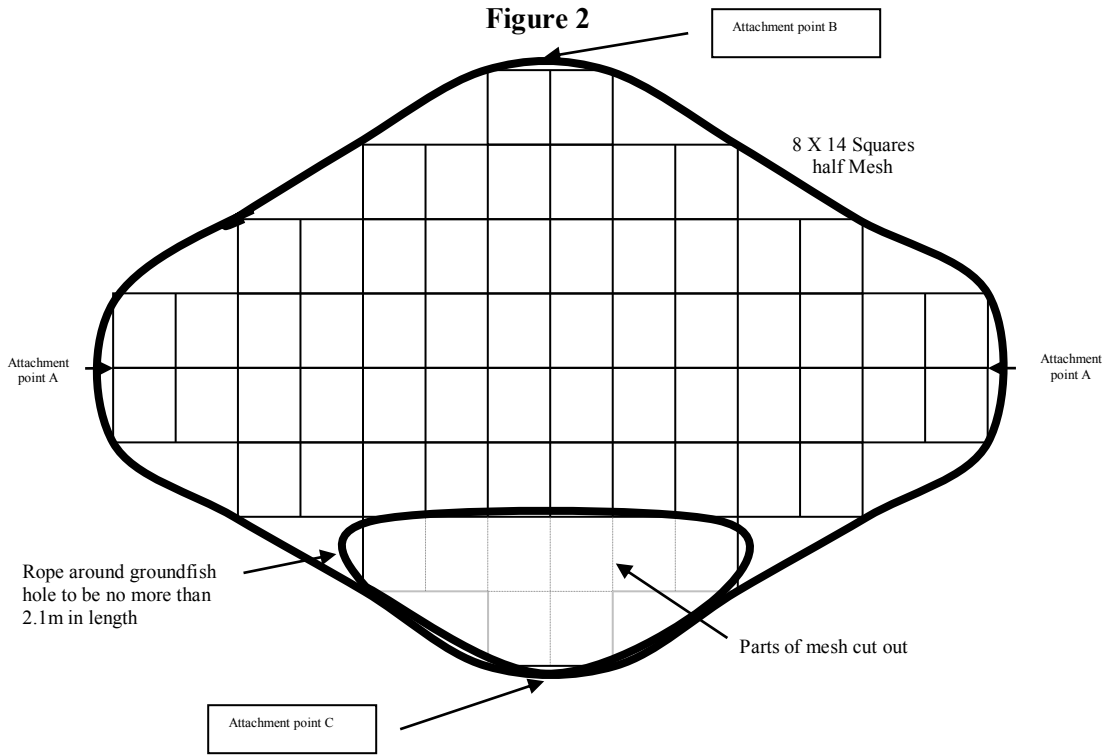

Inclined Panel Top/Side Views

Figure 3

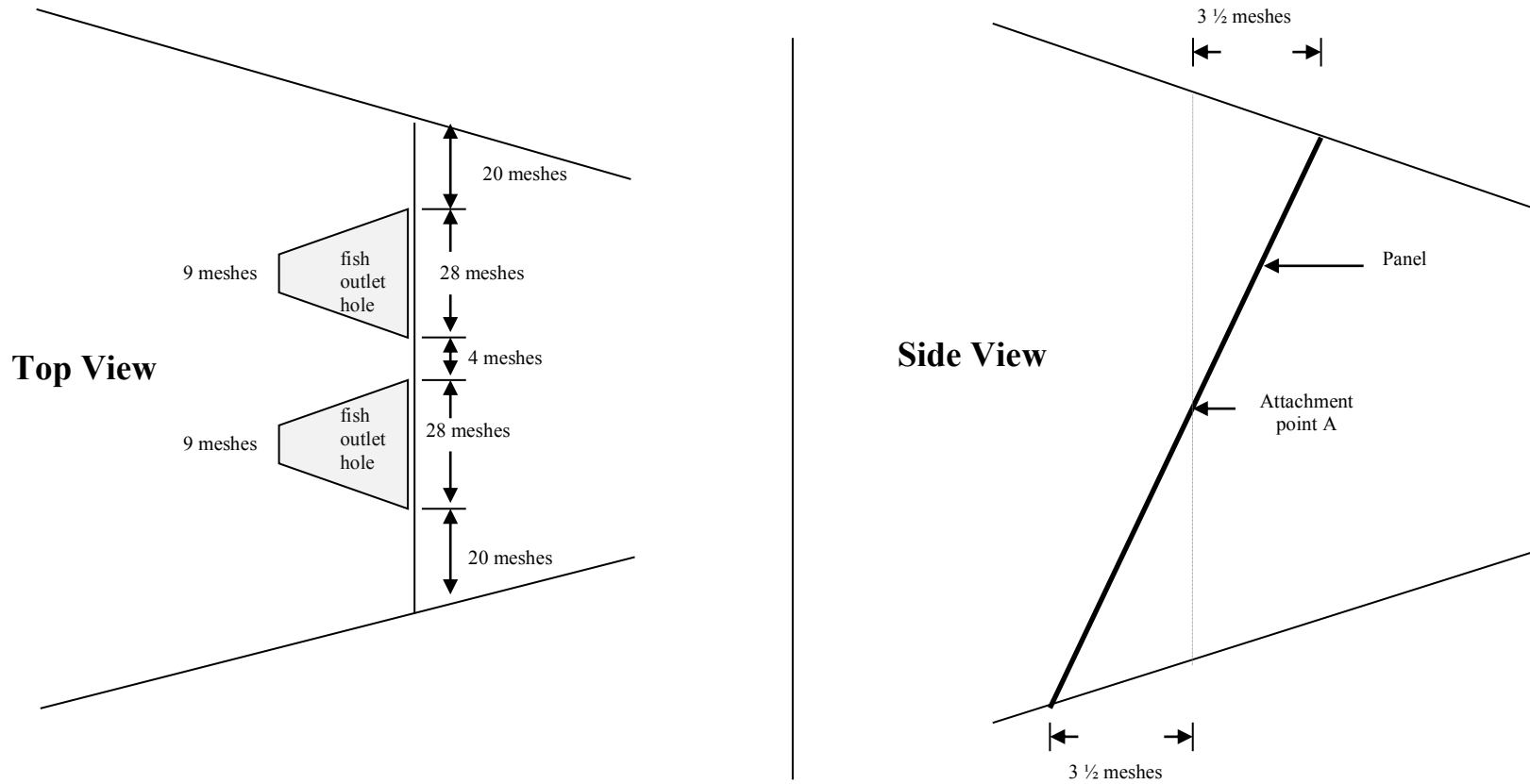

4. Flip-Flap trawl

The Flip-Flap trawl comprises a trawl with large mesh sections to provide for whitefish escape along with a flexible grid that is intended to create a physical barrier to whitefish, especially cod, whilst allowing the passage of Nephrops through to the cod end.

Specifications to be read along with the illustration below:

1. All top wing netting to be made of diamond mesh netting of at least 160mm mesh size.
2. The top sheet netting panel must be made of diamond mesh netting of at least 160mm mesh size. It must extend across the full width of the trawl and extend towards the rear of the net for at least 8m (stretched length).
3. The internal Flip-Flap 'netting' Grid (FFG) must be made from square mesh netting of at most 200mm mesh size and of twine thickness (in the flip flap netting and in attachment to the main body of the net) of no less than 4mm single. It must be positioned no more than 500mm from the rearmost meshes of the end tapered section and:
 - Must be no less than 8 open mesh bars across by 10 open mesh bars deep;
 - The top 8 x 5 bar meshes to be attached to the top netting section between selvages length for length;
 - the lower 8 x 5 bar meshes can be left unattached across the trawls lower netting section but must have leadline (or similar) of weight no less than 1kg/m attached around the edges of its full length;
 - Have an unblocked fish outlet (with clean meshes all the way around) cut out of the trawls top sheet netting immediately ahead of the FFG; and,
 - The opening width of the posterior side of the fish outlet should be no less than 26 x 80mm diamond meshes (or equivalent) across and cut out to a tip in the forward direction along mesh bars;
4. A top sheet square mesh panel (SMP) made from square mesh netting of at least 200mm mesh size must be placed within the end tapered section:
 - The SMP must be no less than 3m long;
 - The SMP must have no fewer than 12 open mesh bars across its width;
 - The rearmost meshes of the SMP must be no more than 0.5m from the forward tip of the unblocked fish outlet.

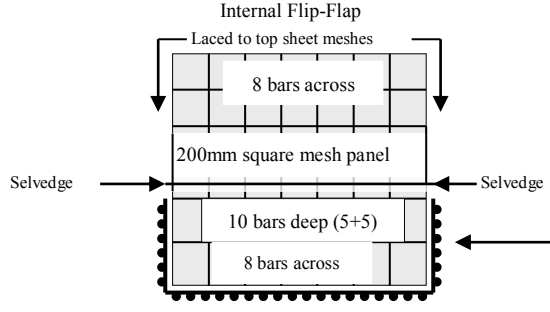
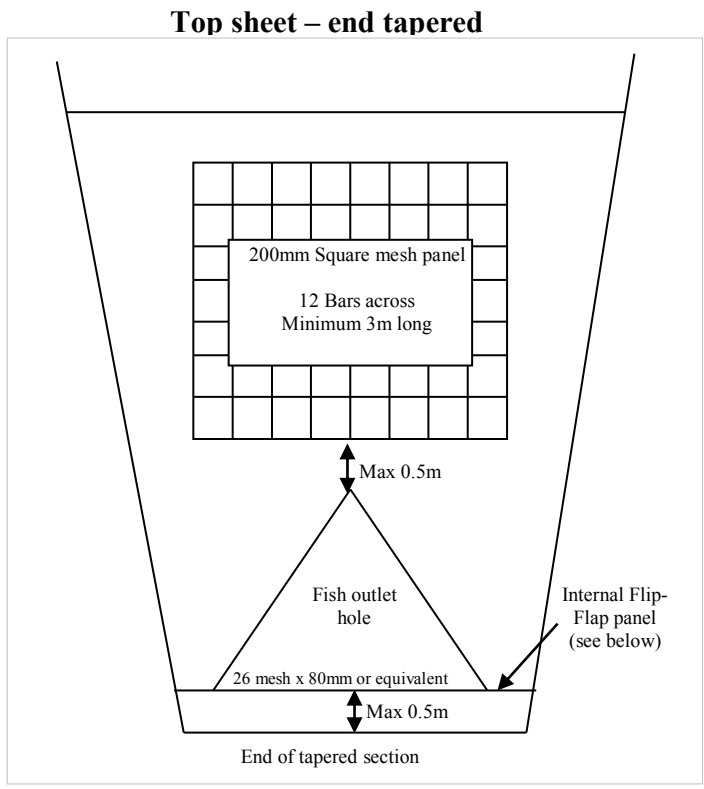

Lower half of panel left unattached and acts as a flapper. Note – heavy leadline (1Kg per m) laced round lower panel edge to provide weight.

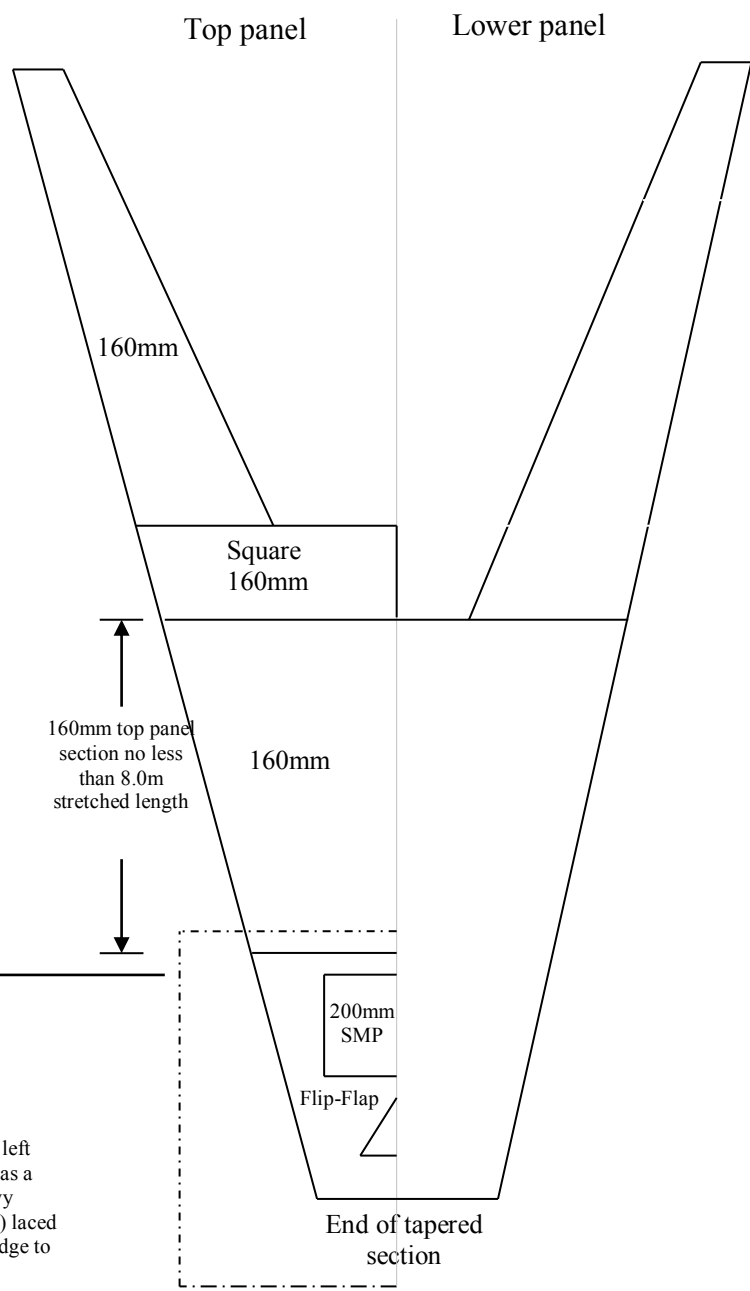

5. CEFAS Net Grid

The Net Grid comprises a wall of netting within the trawl that creates a physical barrier to whitefish while allowing the passage of Nephrops through to the cod end.

Specifications to be read along with the illustrations below:

1. The net grid must be situated between the cod end and the existing square mesh panel.
2. The net grid must be fixed within a four-panel box section (“the box section”), which must be inserted into the two panel trawl.
3. The net grid must be positioned at an incline, at the upper end of which, on the top of the box section, there must be a triangular fish escape hole, the base of which must be 28 meshes wide and formed by cutting along the bar from the outer ends till the sides meet.
4. The netting barrier must be laced to the top and both sides of the box section.
5. The lower end of the netting barrier must be laced to the bottom of the box section for 300mm from the relevant selvedge (each bottom outside corner) towards the centre.
6. The net grid must be constructed of not more than 99mm mesh of twisted twine and attached in a square mesh orientation in parallel with the box section.
7. Two rigid pipes must be (loosely) attached vertically, either side of the net grid on the outside of the box section. These pipes may be unclipped to hang free on the trawl in order to facilitate being wound onto the net drum during hauling.
8. The escape hole is a triangular opening with a flat apex cut in the top sheet of the trawl which allows the escape of fish too large to through the net grid.
9. The escape hole is cut 12 meshes from each corner where the net grid is joined to the top panel of the box section (all bar cut) and extends along the top sheet towards the headline into a triangle, leaving five meshes across at its apex.
10. The escape hole should then be strengthened with nylon twine, pulled tight to form a triangle.

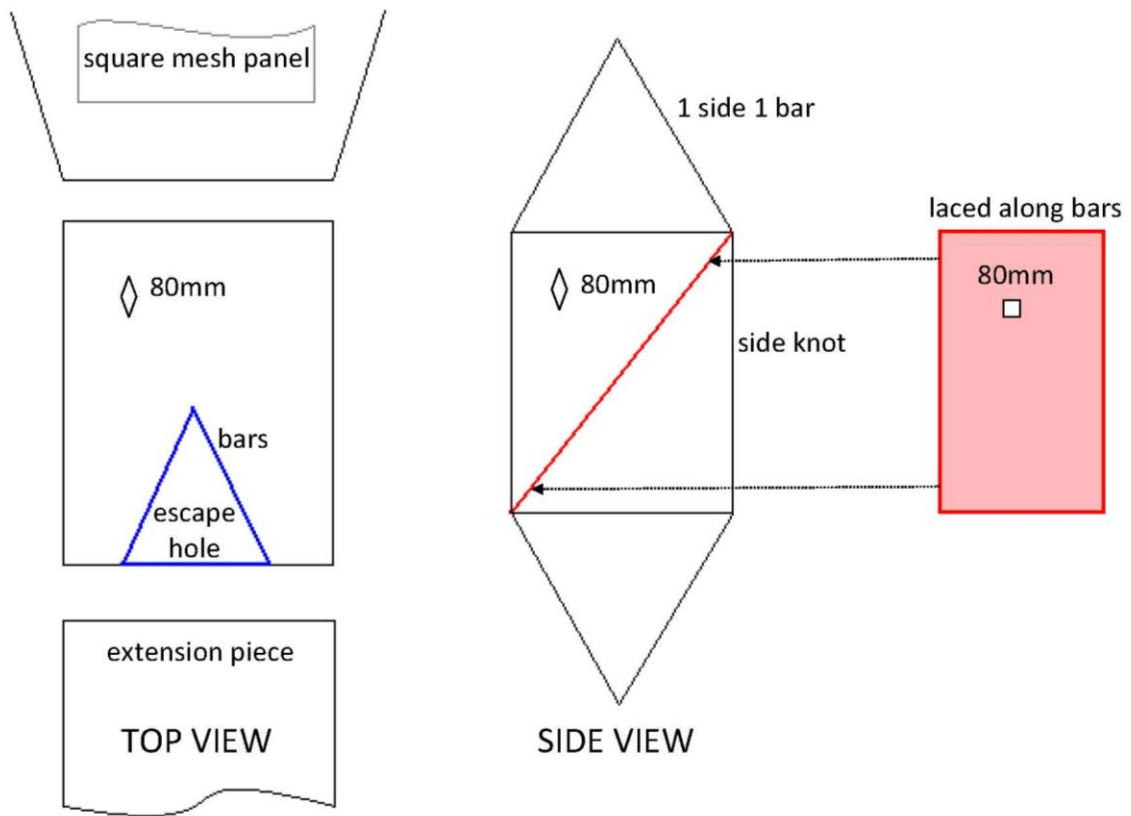

6. Inclined separator panel (specification as per the Annex to EC 254/2002)

The Inclined Separator Panel comprises an 80mm mesh netting separator panel that is intended to create a physical barrier to whitefish, especially cod, whilst allowing the passage of Nephrops through to the cod end.

Specifications to be read along with the illustrations below:

1. The inclined separator panel is within a section approximately 50 meshes long in the last tapered section of the trawl.
2. The panel must be 3m long and set at an angle of approximately 30° to the selvedge of the net.
3. The leading bottom edge of the panel should be horseshoe shaped.
4. The leading edge should be attached to the bottom sheet 0.5 metres below the selvedge and the width of the leading edge at this point should be one third of the width of the top sheet of the net measured from selvedge to selvedge.
5. An escape hole must be provided in the top panel of at least 30 meshes (for 80mm mesh) wide to give a stretched width of 2.4m.
6. The panel can be adjusted by taking in meshes if there seems to be too big a reduction in overall catch. This will adjust the height of the leading edge relative to the bottom sheet. Some slight modification of the panel to fit into small trawls may be required.
7. The critical features of this design for selectivity are:
 - panel mesh no more than 80mm
 - escape opening must be at least 2.4 metres stretched width and must not be obstructed.
 - leading edge must be at least 0.5 metres below the selvedge.

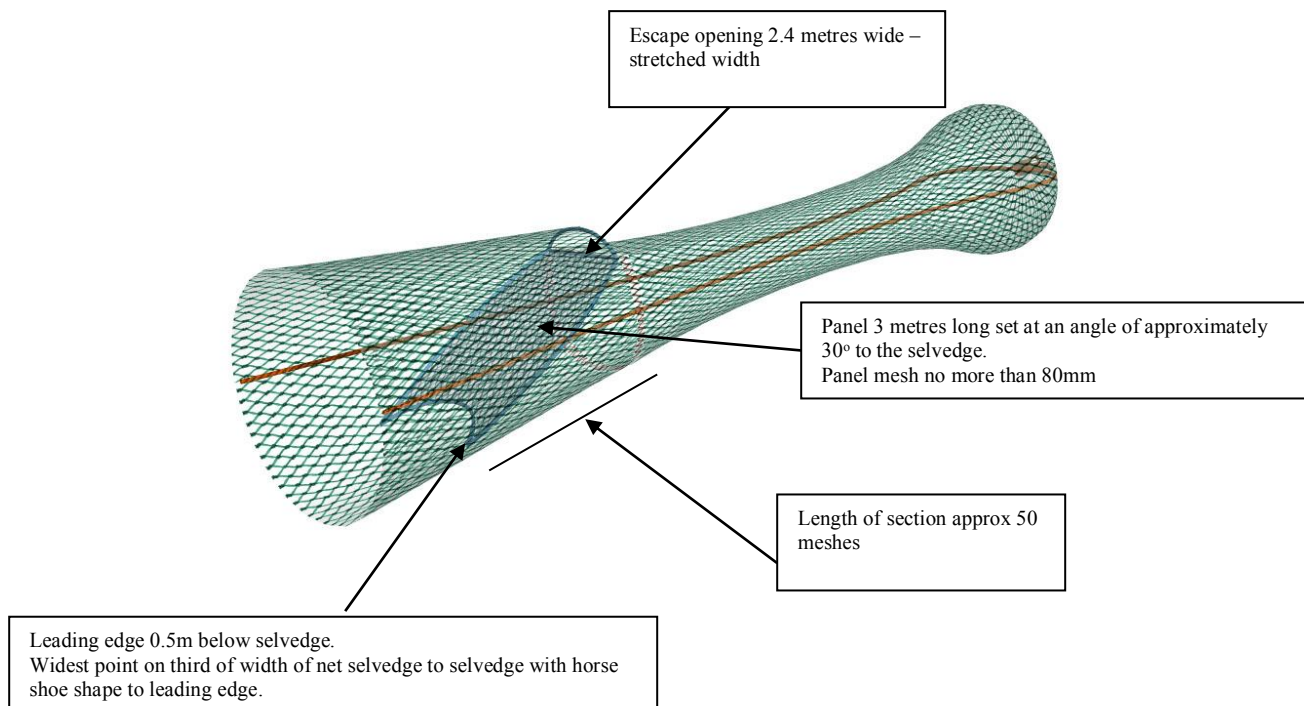

7. Swedish Grid (specification as per the Appendix 2 to Annex III of EC 43/2009)

The Swedish Grid comprises a grid of bars of maximum spacing 35mm inserted into the trawl as well as a square mesh cod end, that is intended to create a physical barrier to whitefish, especially cod, whilst allowing the passage of Nephrops through to the cod end.

This device is considered by the STECF to be highly selective and reduces cod catch to below 1.5%.

Specifications to be read along with the illustrations below:

1. The cod end shall be made of mesh of size no less than 70 mm and smaller than 90 mm. The minimum length of the cod end shall be 8m. Mesh shall be diamond mesh, but optionally square mesh can be used to further improve selectivity if required.
2. It shall be prohibited to use any trawl having more than 100 square meshes in any circumference of the cod end, excluding the joining or the selvages.
3. The grid shall be rectangular with bars parallel to the longitudinal axis of the grid.
4. The bar spacing of the grid shall not exceed 35 mm. It shall be permitted to use one or more hinges in order to facilitate its storage on the net drum.
5. The grid shall be mounted diagonally in the trawl, upwards backwards, anywhere from just in front of the cod end to the foremost end of the straight section. All sides of the grid shall be attached to the trawl.
6. In the upper panel of the trawl there shall be an unblocked fish outlet in immediate connection to the upper side of the grid. The opening of the fish outlet shall have the same width in the posterior side as the width of the grid and shall be cut out to a tip in the anterior direction along mesh bars from both sides of the grid.
7. Optionally it shall be permitted to attach in front of the grid a funnel to lead the fish towards the trawl floor and grid. The minimum mesh size of the funnel shall be 70 mm. The minimum vertical opening of the guiding funnel towards the grid shall be 15 cm. The width of the guiding funnel towards the grid shall be the grid width.

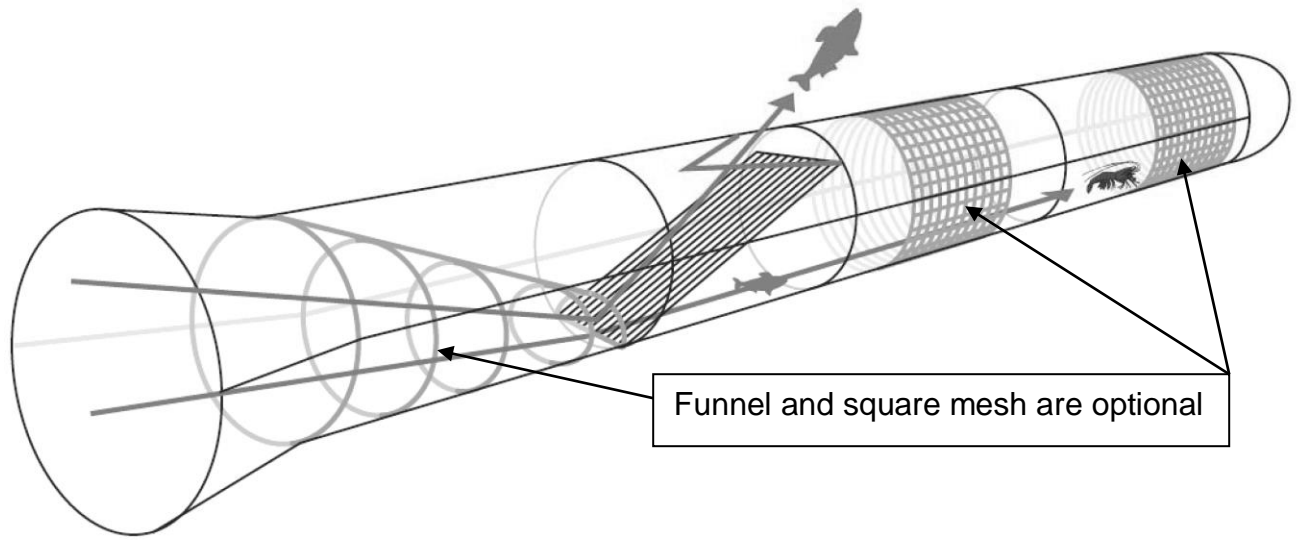

8. 200 square mesh panel (only available for vessels 12 metres and under overall length)

For smaller vessels (12 metres and under) if currently approved panel, grid and box section separation devices are impractical for that vessel, a large square mesh panel may be used. The large SMP is intended to allow whitefish, mainly haddock and whiting to escape whilst allowing the passage of Nephrops through to the cod end.

Specifications to be read along with the illustrations below:

1. The window shall be a rectangular section of netting. The netting shall be single twine. The meshes shall be square meshes, i.e. all four sides of the window netting shall be cut all bars. The mesh size shall be equal or more than 200 mm.
2. The length of the window shall be at least 3 m.
3. The window shall be inserted into the top panel.
4. Location Options:-
 - (a) panel may be located anywhere in the top panel (in accordance with Article 7(2) of EC 850/98) provided that there are no more than five open diamond meshes between the longitudinal side of the window and the adjacent selvedge and the panel may be no less than 750mm wide; **or**.
 - (b) If the rearmost part of the panel is located no more than two metres from the start of the straight extension the panel must be no less than 900mm wide.
5. The stretched length of the window shall be equal to the stretched length of the diamond meshes attached to the longitudinal side of the window. The joining rate between the diamond meshes of the top panel of the cod end and the smallest side of the window shall be three diamond meshes to one square mesh for 80 mm cod end, or two diamond meshes to one square mesh for 200 mm cod end, except for edge bars of the window from both sides.

9 300mm square mesh panel

The 300mm SMP may be used on any vessel regardless of size. The large SMP is intended to allow whitefish, mainly haddock and whiting to escape whilst allowing the passage of Nephrops through to the cod end.

This device is considered by the STECF to be highly selective and reduces cod catch to below 1.5%.

Specifications

1. The window shall be a rectangular section of netting. The netting shall be single twine. The meshes shall be square meshes, i.e. all four sides of the window netting shall be cut all bars. The mesh size shall be equal or more than 300 mm.
2. For knotted netting, 300mm is measured as the distance between the centre of the two opposite knots in the same mesh when fully extended. As this measurement cannot be made with an Omega Gauge manual measurement is required. A maximum tolerance of 10mm is allowed. Any mesh that is less than 290 mm knot centre to knot centre measured diagonally across the extended square may not be used. The bar length shall be at least 150mm between the centre of sequential knots.
3. The length of the window shall be at least 3 m.
4. The window shall be inserted into the top panel.
5. Location Options:-
 - (c) panel may be located anywhere in the top panel (in accordance with Article 7(2) of EC 850/98) provided that there are no more than five open diamond meshes between the longitudinal side of the window and the adjacent selvedge and the panel may be no less than 750mm wide; **or**.
 - (d) If the rearmost part of the panel is located no more than two metres from the start of the straight extension the panel must be no less than 900mm wide.
6. The stretched length of the window shall be equal to the stretched length of the diamond meshes attached to the longitudinal side of the window.